

The SolarPath HIGHLIGHT SP-OPTS™ is the premier LED solar illumination technology in its class today. Ultra-bright/High Intensity LED lighting means a total lighting solution for any need. The solar panel is wrapped and can be installed on a new or an existing pole. It is new technology. This product has both a solar engine and a LED light. The battery and controller are inside pole which allow this product to be used for, roads, parking lot, pathway, etc. The lighting fixture can be used up to 80W and can be controlled via remote control.

Technical Specifications

Solar Module Parameters	Type	High-efficiency Monocrystalline Silicon
	Power	Up to 600W
Solar Charge Controller Parameters	Type	MPPT (Maximum Power Point Tracking), infrared solar charging controller
Battery	LifePO4	Up to 96AH
LED Light Parameters	Light Source Power	Up to 80W (Up to 13,000 lm)
	CCT (Correlated Color Temperature)	3,000K-6,000K/ Amber
	Color Rendering Index (CRI)	≥81
Control Modes	Manual ON/OFF / Automatically ON/OFF / Time Control	
Operation mode	Depend on installation area, can be programed with remote control,	
IP Rating	IP67	
Product size	light body	Depend On LED power
	solar panel	Depend On Solar Panel wattage
Net weight	light body	Depend On LED power
	solar panel	Depend On Solar Panel Wattage

Key features

- Can be installed on existing pole.
- Low installation and maintenance costs.
- Folding solar panel.
- IP 67 Rating.
- Solar powered outdoor lighting.
- Battery, solar controller are built inside of light.
- Good appearance, small size and lightweight, easy to install.
- Rust-proof, dustproof and waterproof.
- Energy saving 100% generated from solar less power consumption than traditional.

Uses and Applications Guide

Streets lighting	●
Parking lots	●
Residential roads	●
Public parks	●
Sports lighting	●

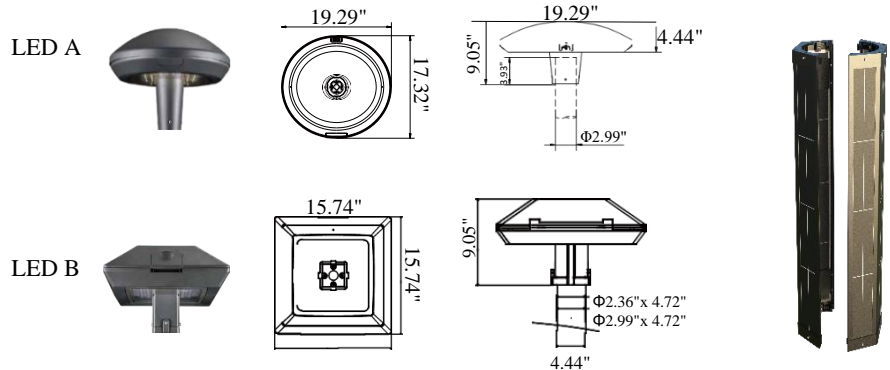

Ordering Guide

EXAMPLE: HIGHLIGHT SP-OPTS -A-100W-A-30W-5-30K-24AH-BLK-00

Model	Solar Panel Quantity	Solar Panel	LED Head	Led Power	Distribution Type	Led Color Temp.	Battery options	LED Body Color	Motion sensor
HIGHLIGHT SP-OPTS™	A - 1	100W	A -	30W	5 - Type V	30K 40K 60K Amber	12AH 18AH 24AH 30AH 36AH 42AH 48AH 54AH	BLK- Black	00 - no motion sensor 01 - motion sensor
	B - 2	120W		40W					
	C - 3	150W	B -	50W					
		180W		60W					
				80W					



*Up on request