

USER MANUAL

of Solar Bollard Light

This solar bollard light offers a futuristic design for public space outdoor lighting applications where the benefits of IK10 vandal resistance are required. LifePO4 battery combined with an intelligent lighting program provides 100% power up to 280lm. The mission of solar bollard light is to comply with the requirement of the Dark Sky Association by limiting the upward light waste ratio (UWLR) to <1%. Limiting upward light reduces environmental light pollution and protects the view of our night sky for all.

We also offer this solar bollard light in a wildlife-friendly version retaining all the features of the original product. Wildlife-Friendly lighting is specifically designed to minimize the ecological impact on animals and insects.

Specification

Solar panel	6.2Watts 5V MONO
LiFePO4 battery	12AH 3.2V
LED power	1.5W max
Luminous output(lm)	280lm
Motion sensor type	PIR
Color temperature	3000K-6000K
Protection rate	IP65 IK10
Light size	φ 10 . 8" H : 35.4"
Certificates	CE, ROHS, IP65, FCC
Working program	4H 100% + 13H 25% with 100% when sensor is triggered

Accessories in package



Expansion Screw : 4 pieces
To tighten the base to ground.
It is M6*2.3"



Allen Wrench : 1 piece
For tightening the two small screws of the light head and at the bottom of the pillar, It also can be used to turn the light ON/OFF.

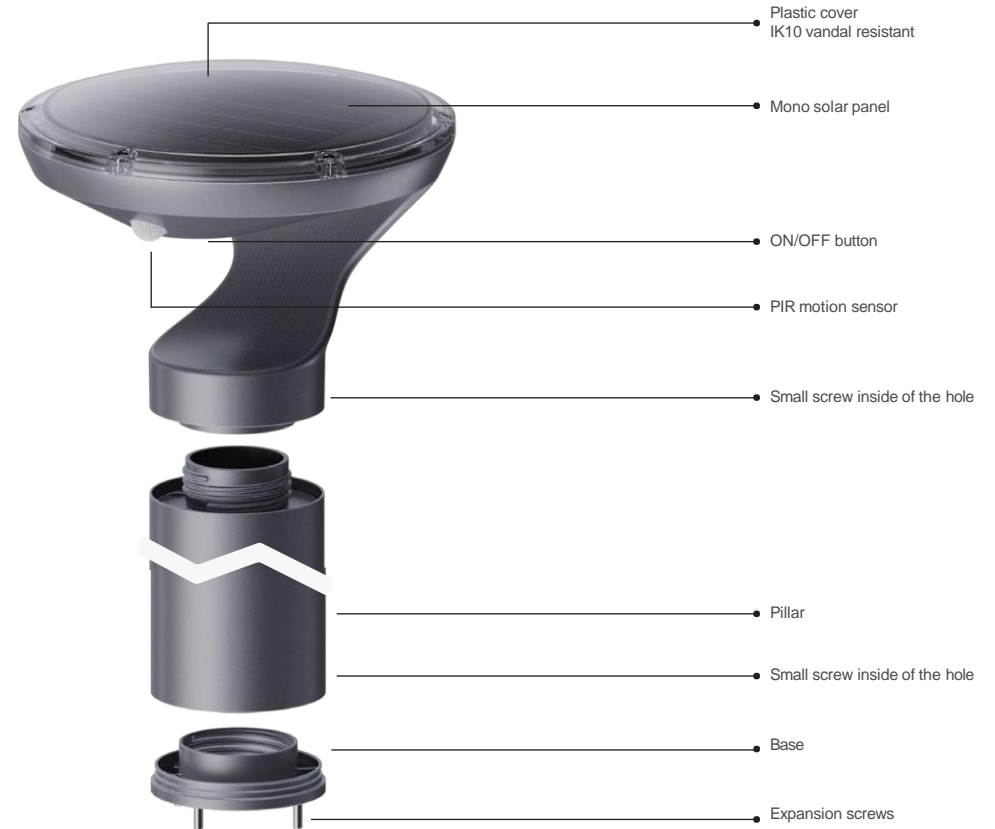

ON/OFF Switch

The ON/OFF switch hole is hidden at the inner position of the light head, in order to reduce the possibility of unexpected operation when it is installed in a public area. Please use the allen wrench to push the on/off.

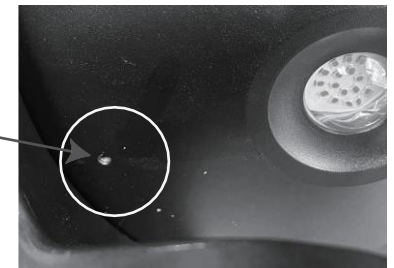

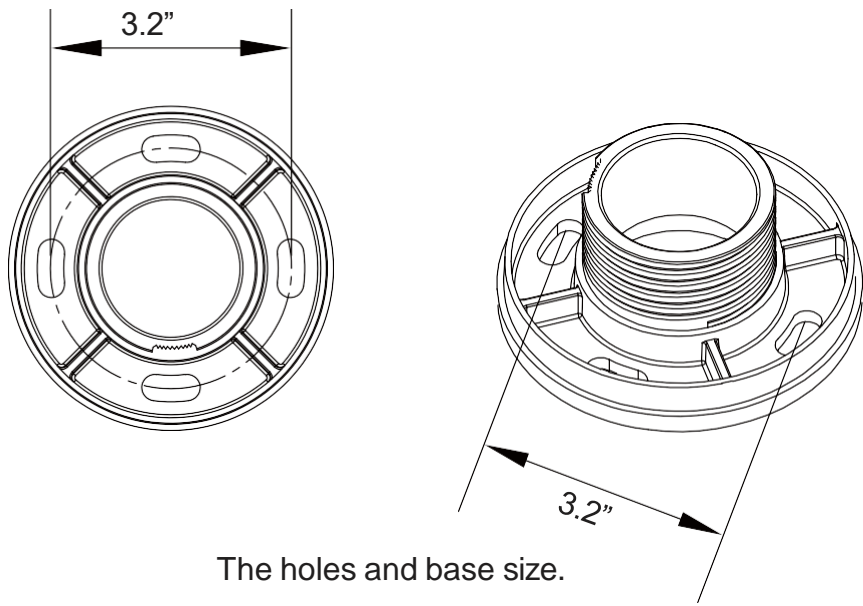

How to install the light

- Step 1 : Drill 4 holes in on the surface according to the size as base dimension shows.
- Step 2 : Screw out the base from the pillar and install it to the surface with 4 screws according to the required lighting direction. (**VERY IMPORTANT STEP**)
- Step 3 : Screw the light head to the pillar properly. (if the light head is separately packed .)
- Step 4 : Use the small screwdriver to tighten the screw inside of the light head to lock it tightly.
- Step 5 : Screw the light body to the base properly and tighten the small screw at the bottom of the pillar to avoid the loosing of light body.
- Step 6 : Use the allen wrench to push the button to turn on the light, then the light will work automatically from dusk to dawn.

Regular Trouble Shot

PROBLEM	REASON	HOW TO SOLVE
Light is off	Switch is off	Turn on the on/off switch of light
	No direct sunshine	Move the light to the direct sunny area
	Continuous cloudy or rainy days	Light will back to work when sun returns
Short working time	There is debris on solar panel	Clean the solar panel
	Location problem	Move the light to the area with direct sunshine
	Continuous cloudy or rainy days	Light will be recharged when sun returns
	Battery life is expired	Replace with a new battery

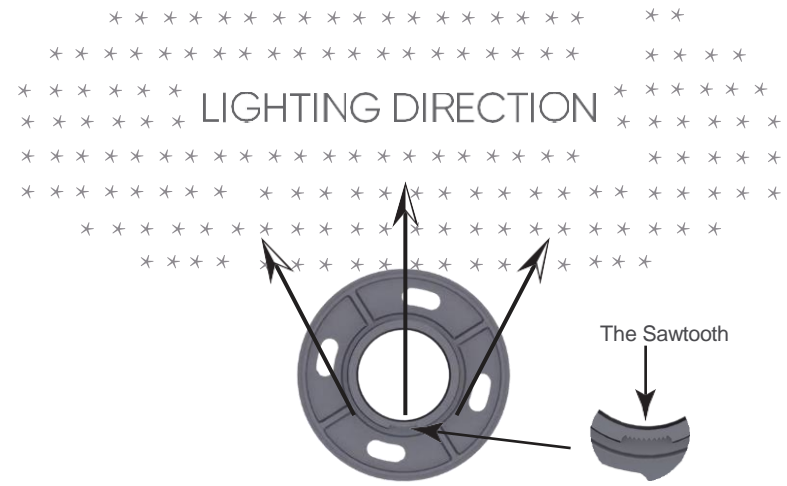

The installation direction of the base directly determines the direction of the lighting, The light will shine in the direction opposite to the sawtooth